

NOTES:

1. MATERIAL:

- 1.1 HOUSING: PBT, UL94 V-0, COLOR: BLUE 285C.
- 1.2 CONTACTS: BRASS
- 1.3 SHELL: BRASS

2. PLATING:

- 2.1 CONTACTS: NICKEL(50u" MIN.) UNDER PLATING OVERALL TIN(80u" MIN.) PLATING ON SOLDER AREA AU(Gold 15U" MIN.) PLATING ON CONTACT AREA
- 2.2 SHELL: NICKEL(50U" MIN.) PLATING OVERALL

3. SPECIFICATION:

- 3.1 CONTACT CURRENT RATING: 1.0 Amp
- 3.2 DIELECTRIC WITHSTANDING VOLTAGE: AC 500V r.m.s.
- 3.3 INSULATION RESISTANCE: 1000MΩ MIN. at DC 250V
- 3.4 CONTACT RESISTANCE: 30 Mini OHM Max(Intial)

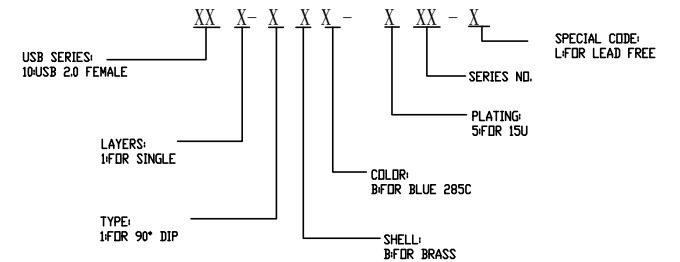
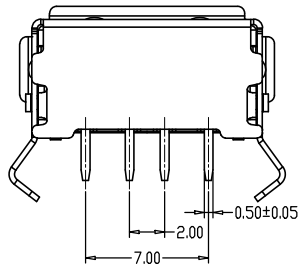
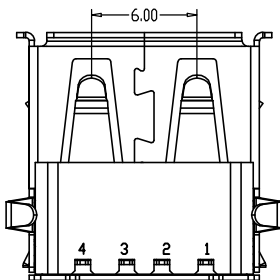
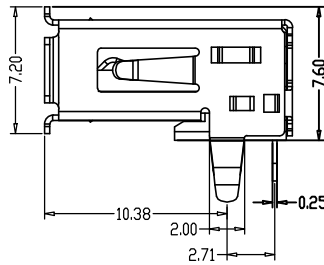
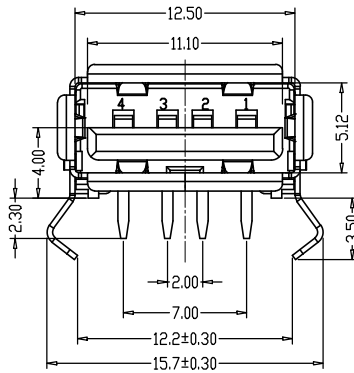

AUTODESK

AUTODESK

廷奕科技股份有限公司  
VITETECH CO., LTD

REV.	ECN.NO.	APP.	DATE
A	Official Publish	YF	OCT/14/12

RoHS COMPLIANT			
DIMENSION CLASSIFICATION ⊙:CRITICAL ⊕:MAJOR < >:REFERENCE			
REVISED	A		
DRAW	CHK'D	APPROVE	DATE
YF	Jack	Stephen	OCT/14/12

PRODUCT	CUSTOMER COPY
SCALE: 1:1	SHEET
UNIT:MM	
GENERAL TOLERANCE X.±0.50 .X ±0.40 .XX ±0.38 .XXX ±0.35 X.' .X'	

PART NO: 101-1BB-562-L
DWG NAME: USB 2.0 A 母 DIP 90度反向 膠芯PBT 外殼 BRASS 285 C