

NOTES:

1. MATERIAL:

- 1.1 HOUSING: PBT, UL94 V-0, COLOR: BLACK.
- 1.2 COVER: LCP UL94 V-0. COLOR: BLACK
- 1.3 CONTACTS: BRASS (T=0.25mm)
- 1.4 SHELL: SUS201 (T=0.30mm)

2. PLATING:

2.1 CONTACTS:

NICKEL (70u" MIN.) UNDER PLATING OVERALL
 TIN (80u" MIN.) PLATING ON SOLDER AREA
 AU (15u") PLATING ON CONTACT AREA

2.2 SHELL: NICKEL (30u" MIN.) PLATING OVERALL
 TIN (60u") PLATING ON KINK

3. SPECIFICATION:

- 3.1 CONTACT CURRENT RATING: 1.5 Amp
- 3.2 DIELECTRIC WITHSTANDING VOLTAGE: AC 500V r.m.s.
- 3.3 INSULATION RESISTANCE: 1000MΩ MIN. at DC 500V
- 3.4 OPERATING TEMPERATURE: -40° C to +105° C
- 3.5 CONTACT RESISTANCE: 30 mΩ MAX.

4. MECHANICAL CHARACTERISTICS:

- 4.1. INSERTION FORCE : 35 N MAX
- 4.2. WITHDRAWAL FORCE : 10N~ 35N
- 4.3. MECHANICAL LIFE: 5000 TIMES

5. INSERTION FORCE OF CONN INTO PCB 2kgf MAX.

6. SALT SPRAY 48HR PASS

PART:

- 10 1 - 5 1 A - 5 41 - L
- 10 : USB 2.0 FEMALE
- 1 : FOR SINGLE
- 5 : FOR UPRIGHT
- 1 : FOR SUS201
- A : FOR BLACK
- 5 : FOR 15u"
- 41 : SERIES NO.
- L : FOR LEAD FREE

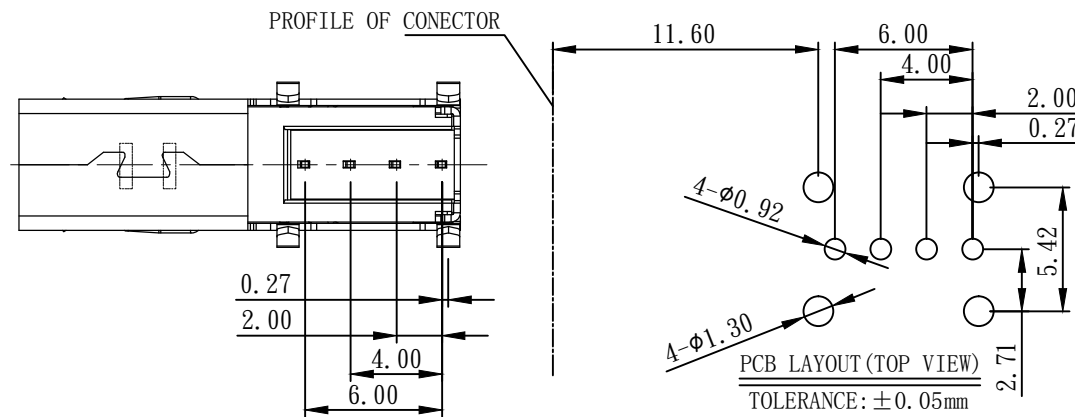
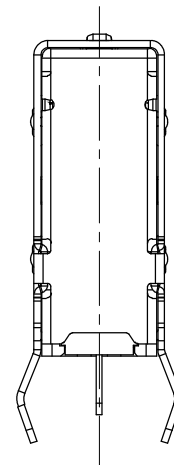
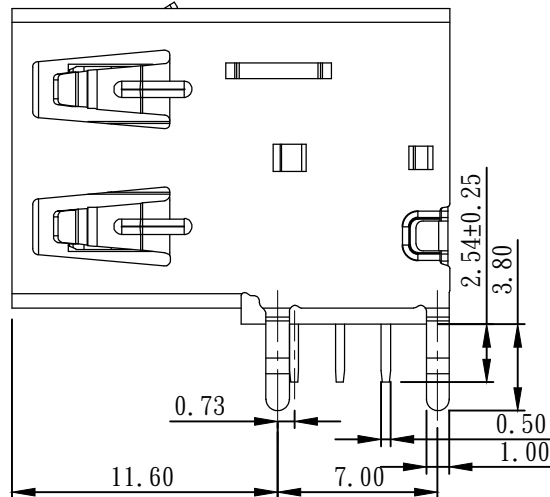
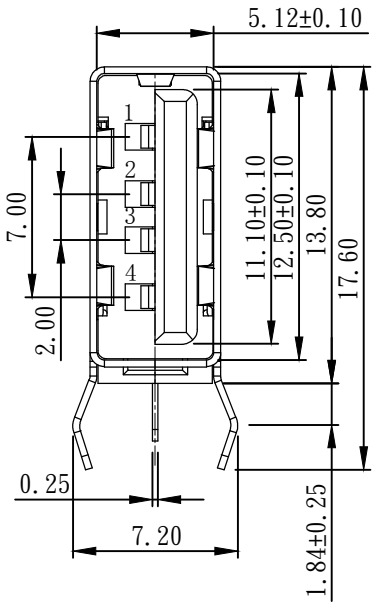
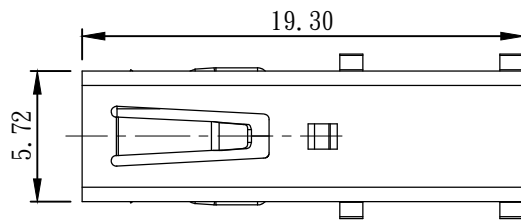

廷奕科技股份有限公司
 VITETECH CO., LTD

| REV. | ECN.NO. | APP. | DATE |
|------|------------------|------|-----------|
| A | Official Publish | OW | MAY/25/11 |

| | | | |
|------------------------------------|-------|---------|-----------|
| RoHS COMPLIANT | | | |
| DIMENSION CLASSIFICATION | | | |
| ⊙: CRITICAL ⊕: MAJOR < : REFERENCE | | | |
| REVISED | A | | |
| DRAW | CHK'D | APPROVE | DATE |
| OW | JACK | ALAN | MAY/25/11 |

| | | |
|---|----------|-------|
| PRODUCT | CUSTOMER | COPY |
| SCALE | 1:1 | SHEET |
| | | |
| GENERAL TOLERANCE X.±0.50 .X ±0.40 .XX ±0.35 .XXX ±0.05 X.' .X' | | |
| UNIT:MM | | |

| | |
|-----------|--------------------|
| PART NO: | 101-51A-541-L |
| DWG NAME: | USB2.0 A/F 側插反向無唇邊 |