

PROFILE OF CONECTOR

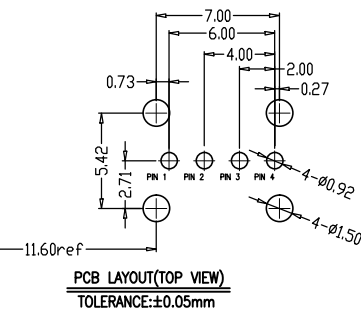

NOTES:

1. MATERIAL:
  - 1.1 HOUSING: PBT, UL94 V-0, COLOR: BLACK
  - 1.2 COVER: LCP, COLOR: BLACK
  - 1.2 CONTACTS: BRASS C2680
  - 1.3 SHELL: SPCC
2. PLATING:
  - 2.1 CONTACTS: NI(50u"MIN.) UNDER PLATING OVER ALL . AU(30U"MIN.) PLATING ON CONTACT AREA. TIN(80u"MIN.) PLATING ON SOLDER AREA.
  - 2.2 SHELL: NI(50U"MIN.) UNDER PLATING OVER ALL.
3. SPECIFICATION:
  - 3.1 CONTACT CURRENT RATING: 1.0 Amps. 30V AC
  - 3.2 DIELECTRIC WITHSTANDING VOLTAGE: AC 500V r. m. s.
  - 3.3 INSULATION RESISTANCE: 1000MΩ MIN. at 250V DC
  - 3.4 CONTACT RESISTANCE: 30 MINI Ω MAX(INTIAL).

HOW TO ORDER

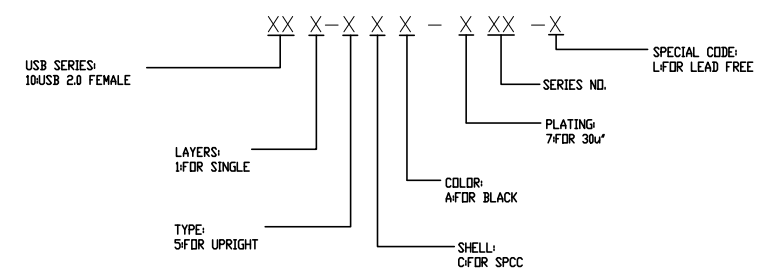

廷奕科技股份有限公司  
VITETECH CO., LTD

REV.	ECN.NO.	APP.	DATE
A	Official Publish	EMILY	MAY/25/11

RoHS COMPLIANT			
DIMENSION CLASSIFICATION			
⊙:CRITICAL ⊕:MAJOR < :REFERENCE			
REVISED	A		
DRAW	CHK'D	APPROVE	DATE
Alan	Jack	EMILY	MAY/25/11

PRODUCT	CUSTOMER COPY
SCALE: 1:1	SHEET
GENERAL TOLERANCE	
X.±0.50	.X ±0.40
.XX ±0.25	
.XXX ±0.05	
X.'	.X'
UNIT:MM	

PART NO:101-5CA-767-L
DWG NAME:
USB A/F UPRIGT R/A DIP 4P