

NOTES:

1. MATERIAL:
 - 1.1 HOUSING: PBT, UL94 V-0, COLOR: BLACK.
 - 1.2 CONTACTS: C2680
 - 1.3 SHELL: SPCC
2. PLATING:
 - 2.1 CONTACTS:
NICKEL (50u" MIN.) UNDER PLATING OVERALL
TIN (80u" MIN.) PLATING ON SOLDER AREA
AU (Gold Flash.) PLATING ON CONTACT AREA
 - 2.2 SHELL: NICKEL (50u" MIN.) PLATING OVER
Cu (50u" MIN.) UNDER PLATING OVERALL
3. SPECIFICATION:
 - 3.1 OPERATING TEMPERATURE: -55°C~105°
 - 3.2 CONTACT CURRENT RATING: 2 Amp
 - 3.3 DIELECTRIC WITHSTANDING :
AC 500V/min. R. M. S, VOLTAGE RATING 12 DC
 - 3.4 INSULATION RESISTANCE: 500Mvmin. at 500V DC
 - 3.5 CONTACT RESISTANCE: 30mV Max

PART NO.

71 1 - 9 C 5 - 1 23 - L

- 71 : MID
 1 : LAYERS FOR SINGLE

 9 : FOR 9 PIN
 C : SHELL FOR STEEL ALLOY
 5 : COLOR FOR BLACK

- 1 : PLATING FOR G. F
 23 : SERIES NO.

L : FOR LEAD FREE

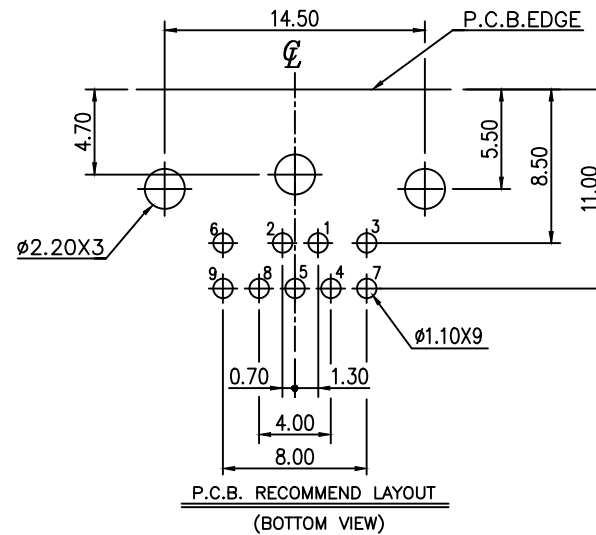
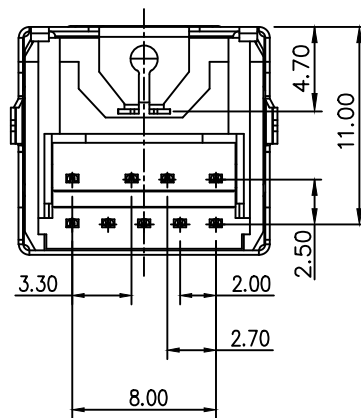
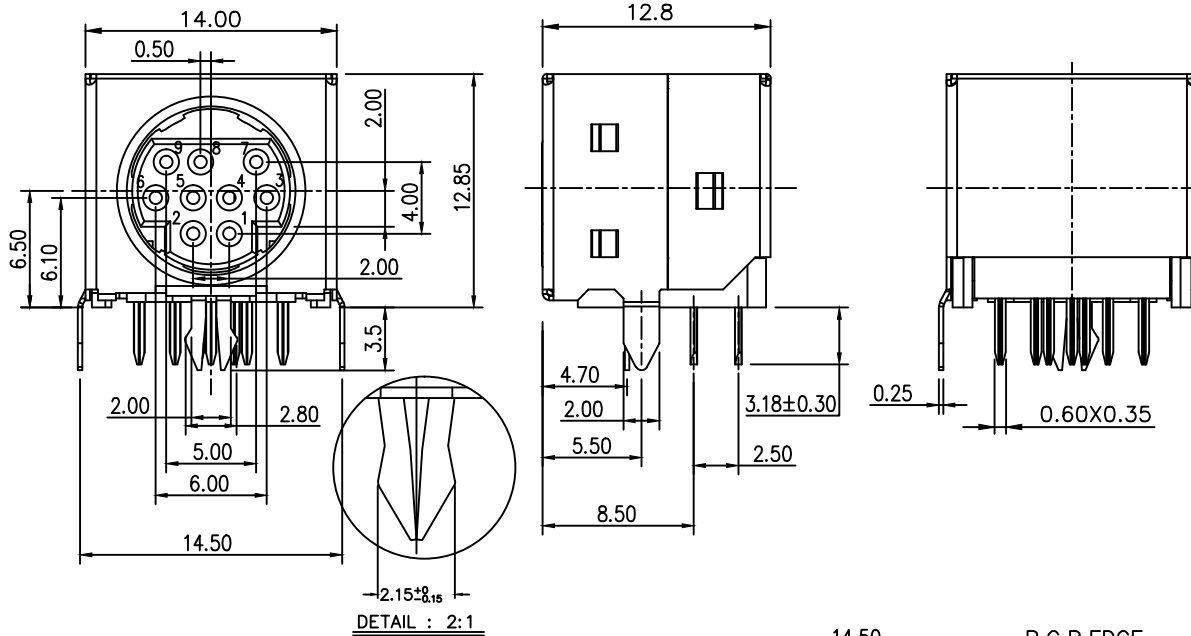

廷奕科技股份有限公司
 VITETECH CO., LTD

REV.	ECN.NO.	APP.	DATE
A	Official Publish	OW	MAY/25/11

RoHS COMPLIANT			
DIMENSION CLASSIFICATION			
⊙: CRITICAL Ⓞ: MAJOR (): REFERENCE			
REVISED	A		
DRAW	CHK'D	APPROVE	DATE
OW	Jack	Emily	MAY/25/11

PRODUCT CUSTOMER COPY	
SCALE	SHEET
1:1	
GENERAL TOLERANCE	
X.±0.50	.X ±0.45
.XX ±0.30	
.XXX ±0.05	
X.'	.X'

PART NO: 711-9C5-123-L
DWG NAME: MINI DIN 9 PIN